



Single Handle Tub/Shower Pressure Balancing Valve

- 1/2" Uponor or Cold Expansion PEX Inlet W/Combo CXC & IPS Outlet
- Pressure Balancing Cartridge Ships with Trims
- Brass Inlet Stops With Backflow preventors
- Stainless Steel Mounting Bracket
- Test Cap allows Pressure Testing 150 PSI Max
- Square Mud Guard with Leveler allows right angle cuts
- Thin Wall Mounting
- Back to Back Installation

Olympia products are engineered and manufactured to meet the following standards and codes :
 ASME A112.18.1/ CSA B125.16
 ASSE 1016
 ASTM F1960
 IAPMO LISTED



Note: Valve can be tested When Test Cap installed with air (150 PSI) or water (150 PSI).

Note: Cartridge operational at pressures 20 PSI to 100 PSI.

V-2307B Flow Rate (GPM) Vs Pressure (PSI) For Tub Port*

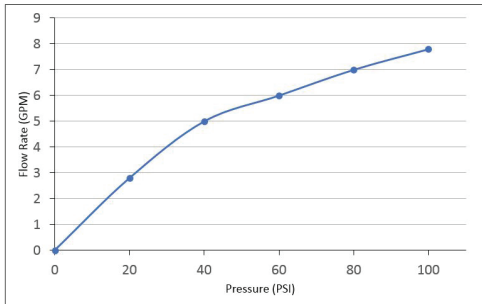

*Note: This information is provided for reference only. Actual Flow Rate may vary depending on installation and inlet pressures.

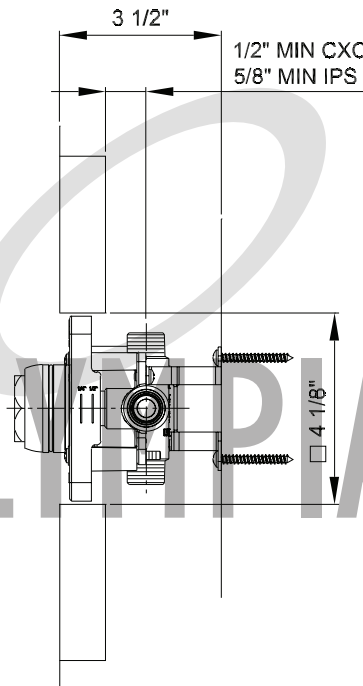
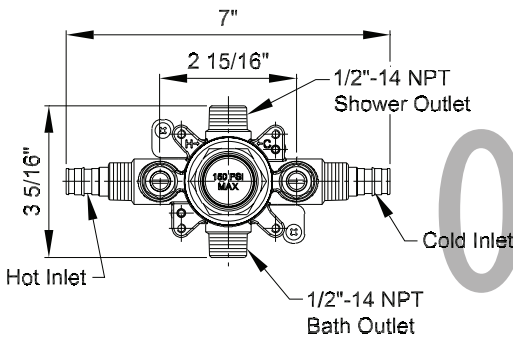

THICK WALL

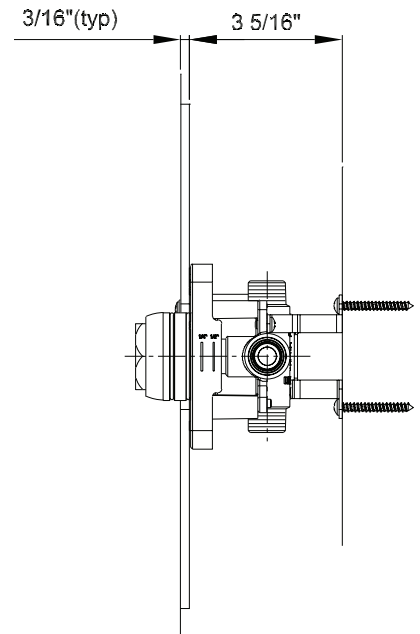

THIN WALL